

# CROSS STACK LASER GAS ANALYZER

## (Single beam version)

DATA SHEET

ZSS-S

Cross stack laser gas analyzer (ZSS) provides continuous measurement of HCl contained in flue gas in waste incineration plants and industrial waste disposal facilities, NH<sub>3</sub> in power plants and denitration equipment, CO, CO<sub>2</sub>, and O<sub>2</sub> in iron and steel plants and chemical plants with high speed response. Because ZSS is installed directly on the stack or the pipe through which the target gas passes, sample gas conditioning is not required. Being highly tolerant to dust, ZSS can be installed on the upstream of a bug filter where the gas sampling is usually difficult. ZSS is the first laser gas analyzer in Japan that is designed for environmental monitoring and process monitoring.

### FEATURES

1. Low maintenance
2. Low operating-cost: with no gas-sampling device and few parts to be replaced
3. Superior long-term stability
4. Fast response within 2 seconds
5. Tolerant to high temperature and high dust
6. Environment friendly: 80 VA, low power consumption
7. Analog output for transmittance is available
8. Compliant with RoHS directive



### SPECIFICATIONS

Table 1. Measurable components and range limits:

No. of components	Component	Minimum range *1	Maximum range *1	Gas temperature	Purge gas	4th digit
1	HCl	10 ppm	5000 ppm	≤ 400°C	Instrument air	C
	NH <sub>3</sub>	15 ppm	5000 ppm	≤ 450°C		W
	CO (High level)	2 vol%	100 vol%	≤ 300°C		A
	CO (Low level)	200 ppm	1 vol%	≤ 400°C		M
	CO <sub>2</sub>	2 vol%	100 vol%	≤ 300°C		G
	CH <sub>4</sub>	100 ppm	100 vol%	≤ 300°C		R
	O <sub>2</sub>	10 vol%	100 vol%	≤ 300°C	N <sub>2</sub>	P
	O <sub>2</sub> (High temperature)	4 vol%	100 vol%	≤ 1200°C		Q
	O <sub>2</sub> (Instrument air purge)	25 vol%	100 vol%	400–1200°C		T
2	HCl + H <sub>2</sub> O (50 vol%) *2	50 ppm (HCl)	1000 ppm (HCl)	130–400°C	Instrument air	F
	NH <sub>3</sub> + H <sub>2</sub> O (50 vol%) *2	50 ppm (NH <sub>3</sub> )	1000 ppm (NH <sub>3</sub> )	≤ 450°C		X
	CO + CO <sub>2</sub>	2.5 vol%	100 vol%	≤ 300°C		K

Notes:

1. The minimum and maximum measuring range shown in the above table are for a measuring path length (stack length) of 1m. See the "calculation method" below for other path lengths.
2. Consult us if you select the H<sub>2</sub>O measuring version.

#### • Calculation method of measuring range for optical path lengths other than 1m

Measuring range = [Minimum or maximum range ÷ path length]

Example. 1)

HCl analyzer, path length 5m  
 Upper limit: 5,000ppm ÷ 5m = 1,000ppm  
 Lower limit: 10ppm ÷ 5m = 2ppm  
 Therefore, measuring range is between 0 to 2 …1,000ppm

Example. 2)

HCl analyzer, path length 0.5m  
 Upper limit: 5,000ppm ÷ 0.5m = 10,000ppm  
 Lower limit: 10ppm ÷ 0.5m = 20ppm  
 Therefore, measuring range is between 0 to 20 …10,000ppm

**Measurement principle:**

Non-dispersive infrared (NDIR)

**Measuring method:**

Cross-stack system (path system)

**Application:**

Waste incineration plant, industrial waste disposal facility, power plant iron and steel plant, paper plant, pulp mill, chemical plant and bioplant, etc.

**Light source:**

Near-infrared laser

**Laser class:**

Class 1 (High temperature version and instrument air purge version fall under CLASS 3B)

**Dimensions:**

Refer to outline diagram

**Weight (excluding cables):**

Receiver unit and transmitter unit: Approx. 10 kg

Control unit: Approx. 8 kg

**Structure:**

Outdoor use, dustproof and rainproof (IP65)

**Finish color:**

Receiver/Transmitter box: gray

Control unit cover: blue

Control unit case: silver

**Material:**

Receiver unit and transmitter unit: aluminum, stainless steel 316

Control unit: Aluminum

**Materials of gas-contacting parts:**

Stainless steel 316, BK7, FKM, PTFE, glass-cloth, silicone

**Air purge connection diameter:**

RC1/4 (tube connection: 10/8)

**Power supply:**

Rated voltage: 100–240 V AC (operating voltage: 90–264 V AC)

Rated frequency: 50/60 Hz

**Power consumption:**

80 VA or less

**Display:**

Backlit LCD

**Display contents:**

Component, concentration (instantaneous value, average value O<sub>2</sub> correction instantaneous value and O<sub>2</sub> correction average value), alarm (fault status)

**Communication:**

RS-485 (Modbus)

**Cable length:**

Receiver unit to transmitter unit: Standard 2 m (Maximum 25 m)

Receiver unit to control unit: Standard 5 m (Maximum 100 m)

**Analog output:**

No insulation, 2 or 4 points

Signal	Allowable load
4–20 mA DC	≤ 550 Ω
1–5 V DC	≥ 500 kΩ

(Transmits the measured value and the O<sub>2</sub>-corrected value, and/or the transmittance (%T). User can switch between average values and instantaneous values.)

**Analog input:**

4–20 mA DC, 2 points

Measured gas pressure, measured gas temperature, measured gas velocity, O<sub>2</sub> concentration, H<sub>2</sub>O concentration, or air purge pressure

\* Analog inputs are used for the concentration compensation, the O<sub>2</sub> correction, and the alarm output.

**Digital output:**

6 points, SPST-NO (standard) or SPST-NC

Relay contact, contact capacity 24 V DC, 1 A (resistive load)

Low light transmission, device failure, during hold/during calibration, H/L limit, environmental error, power interruption

**Digital input (option):**

3 points

Voltage input, received by photocoupler (operating voltage 12–24 V DC, current 5–20 mA)

Average value reset, switchover between instantaneous value and moving average value, remote hold

**PERFORMANCE**

(at 25°C and 0.1 MPa, excluding H<sub>2</sub>O measurement)

**Repeatability:**

±1.0% FS (depends on component, range, optical path length)

**Linearity:**

±1.0% FS (depends on component, range, optical path length)

**Zero point drift:**

±2.0% FS per 6 months (depends on component, range, optical path length)

**Span drift:**

±3.0% FS per 6 months (depends on component, range, optical path length)

**Cross interference:**

±2.0% FS

**Notes:**

1. The amount of some gases (e.g. HCl, NH<sub>3</sub>) adsorbed by water or other substances are not counted.
2. Consult us with regard to the performance of H<sub>2</sub>O analysis.
3. There may be some difference in measured concentration between the laser gas analyzer and manual analysis or other kinds of gas analyzers, depending on measuring environment (moisture concentration, pressure broadening, temperature, pressure, and/or purge gas flow rate).
4. Indication adjustment with manual analysis or other gas analyzers is provided with charge, only when requested.

**Detection limit:**

1% of minimum range

**Response time (for 90% FS response):**

≤ 2 s

**Warm-up time:**

≤ 90 min

**FUNCTIONS****DIGITAL OUTPUT****Low light transmission:**

Contact is opened or closed when the intensity of the light reached the receiver is deficient.

**Device failure:**

Contact is opened or closed when any of the followings occurs: Laser temperature error, light intensity high, communication error

**During hold/during calibration:**

Contact is opened or closed during the analog output is held (to the last value or the user-defined value) and during calibration.

**H/L limit:**

Contact is opened or closed when the measured value has gone beyond the high limit or below the low limit.

**Environmental error:**

Contact is opened or closed when the gas temperature is outside the range, air purge pressure is too low, analog input signal is abnormal, and/or box temperature is abnormal.

**Power interruption:**

Contact is opened or closed during the power supply to the analyzer is interrupted.

## DIGITAL INPUT (OPTION)

### Average value reset signal:

Output of converted average value is started from the initial state by applying rectangular-wave voltage (with a minimum pulse width of two seconds) to the input terminal of average value resetting. Output is reset by inputting and restarted by opening.

### Switchover between instantaneous value and moving average value:

Switching to and from the instantaneous value and the average value of the analog output is performed by applying rectangular-wave voltage (with a minimum pulse width of two seconds) to the input terminal for switching between the instantaneous value and the moving average values.

### Remote hold:

The analog output is held by applying voltage to the remote hold input terminal. The hold is cancelled by opening the relay contact.

## O<sub>2</sub> CORRECTION

Conversion of measured gas concentrations into values at reference O<sub>2</sub> concentration

Correction formula:

$$C = \frac{21 - O_n}{21 - O_s} \times C_s$$

C: Converted concentration

C<sub>s</sub>: Measured concentration of sample gas

O<sub>s</sub>: Measured O<sub>2</sub> concentration (Upper limit settable between 1 and 20%)

O<sub>n</sub>: Reference O<sub>2</sub> concentration (changeable between 0 and 19%)

The result of calculation is indicated and output in an analog output signal.

## DRY/WET VALUE OUTPUT

A user can switch the indication and the output between wet values (concentrations which include moisture) and dry values (concentration from which the moisture content is eliminated). The moisture concentration can be set by key or by the analog input.

## SAMPLE GAS REQUIREMENTS

### Temperature:

Refer to Page 1.

\* For measurement of high temperature gas of 500°C or above, install a pressure sensor on the purge line to monitor the purging status. If the purge is suspended under the high temperature gas environment, the product may be seriously damaged.

### Pressure:

±10 kPa (Consult us if the gas pressure exceeds this limit.)

### Moisture:

≤ 50 vol% (no condensation)

### Velocity:

Flow velocity (m/s) = purge gas flow rate of each side (L/min) / 10

### Dust (when the optical path length is 1 m):

Standard version: ≤ 5 g/m<sup>3</sup> (N)

Dust resistant version:

O<sub>2</sub> measurement: ≤ 10 g/m<sup>3</sup> (N)

Low level CO: ≤ 20 g/m<sup>3</sup> (N)

Others: ≤ 15 g/m<sup>3</sup> (N)

Consult us if your application has high dust. Dust resistance varies with the target gases, specification, optical path length, particle size of dust, and other conditions.

## INSTALLATION ENVIRONMENT

### Ambient temperature:

-20°C to +55°C (receiver unit and transmitter unit)

-5°C to +45°C (control unit)

### Ambient humidity:

≤ 90% RH

### Storage conditions:

Temperature: -20°C to +60°C

Humidity: ≤ 95% RH

### Optical path length:

0.5 m to 10 m

\* Consult us if the distance between the transmitter unit and the receiver unit is beyond 10 m.

### Standard flange:

JIS 10K 50A flange (JIS B 2212)

### Purge gas:

Instrument air

(If not available, a compressor is required. The air shall contain neither oil nor mist.)

Use N<sub>2</sub> if the target gas contains explosive gas or combustible gas, and for O<sub>2</sub> analyzers other than the instrument air purge version.

### Purge gas pressure:

≥ 0.3 MPa (depending on the flow velocity of target gas)

### Purge gas flow rate:

≥ 20 L/min (depending on measured gas velocity)

Flow rate of each purge line (50A pipe) (L/min) = measured gas flow velocity (m/s) × 10

Two purge lines are required

### Vibration:

0.5 G or less (0.2 G or less when the frequency range is 20 to 40 Hz) (when optical path length is 1 m)

### Mounting angle:

Horizontally ±5 degrees or less (No dew condensation should accumulate on the window.) Refer to Page 11.

## CALIBRATION

### Cycle:

Every 6 months (the cycle may vary depending on the installation environment)

### Method:

Remove the transmitter and the receiver from the stack, attach them to the calibration cells, and flow the standard gas with a flow rate of 1.5 to 2.0 L/min. (calibration cells and standard gas are to be prepared separately)

### Zero gas:

Dry N<sub>2</sub>

### Span gas:

80% to 100% concentration of each range × optical path length, balance N<sub>2</sub>  
(when the calibration cell is 1 m)

## EC DIRECTIVE COMPLIANCE

### LVD (2014/35/EU)

EN 61010-1

EN 62311

EN 60825-1

### EMC (2014/30/EU)

EN 61326-1 (Table 2)

EN 61000-3-2 (Class A)

EN 61000-3-3

EN 61326-2-3

### RoHS (2011/65/EU+(EU)2015/863)

EN IEC63000

**CODE SYMBOLS**

When ordering, be sure to submit the order sheet on the last page of this Data Sheet.

ZSS       8 -   A  -   0   -   N  Note 8)

Digit	Specification	Note	Code	
4	Components	Note 1	CO	A
			CO (low-level)	M
			HCl	C
			HCl + H <sub>2</sub> O (50 vol%)	F
			CO <sub>2</sub>	G
			CO + CO <sub>2</sub>	K
			O <sub>2</sub>	P
			O <sub>2</sub> (High temperature)	Q
			O <sub>2</sub> (Air purge)	T
			CH <sub>4</sub>	R
			NH <sub>3</sub>	W
NH <sub>3</sub> + H <sub>2</sub> O (50 vol%)	X			
5	Unit		ppm	1
			mg/m <sup>3</sup>	3
			vol%	5
			ppm (1st comp), vol% (2nd comp)	7
			vol% (1st comp), vol% (2nd comp)	9
6	Measuring range (1st component)	Note 2, 3	0 to 2	K
			0 to 2.5	Q
			0 to 4	S
			0 to 5	L
			0 to 10	V
			0 to 15	0
			0 to 20	1
			0 to 25	T
			0 to 50	A
			0 to 100	B
			0 to 200	C
			0 to 250	D
			0 to 400	J
			0 to 500	E
			0 to 1000	F
			0 to 2000	G
			0 to 5000	H
0 to 6000	M			
Others	X			
7	Measuring range (2st component)	Note 7	None	Y
			0 to 2	K
			0 to 2.5	Q
			0 to 4	S
			0 to 5	L
			0 to 10	V
			0 to 15	0
			0 to 20	1
			0 to 25	T
			0 to 50	A
			0 to 100	B
			0 to 200	C
			0 to 250	D
			0 to 400	J
			0 to 500	E
			0 to 1000	F
			0 to 2000	G
0 to 5000	H			
0 to 6000	M			
Others	X			
9	Flange rating		10K 50A (JIS B 2212)	A
			10K 100A	B
			DN50/PN10	C
			ANSI #150 2B	D
10	Number of analog output points		2 points	0
			4 points	1
11	Number of analog input points		2 points	A

Digit	Specification	Note	Code				
12	Analog output		4 to 20mA DC	1			
			1 to 5V DC	5			
13	DI/DO		6 output points, No input	0			
			6 output points, 3 input points	1			
14	Cable length between receiver and control unit	Note 4	5m	A			
			10m	B			
			20m	C			
			30m	D			
			40m	E			
			50m	F			
			80m	G			
			100m	H			
			Others	X			
			15	Cable length between receiver and transmitter	Note 5	2m	A
						5m	B
10m	C						
15m	D						
20m	E						
16	Language		Japanese	J			
			English	E			
			Chinese	C			
17	-		0				
18	Optical path length (ones place)	Note 6	0m	0			
			1m	1			
			2m	2			
			3m	3			
			4m	4			
			5m	5			
			6m	6			
			7m	7			
			8m	8			
9m	9						
19	Optical path length (tenths place)	Note 6	0.0m	0			
			0.1m	1			
			0.2m	2			
			0.3m	3			
			0.4m	4			
			0.5m	5			
			0.6m	6			
			0.7m	7			
			0.8m	8			
0.9m	9						
20	Optical path length (hundredths place)	Note 6	0.00m	0			
			0.05m	5			
			(Used only when 10m is specified)	9			
21	-		N				
22	High-dust version (High-speed AGC)		No	N			
			Yes	H			

- Note 1) Consult us when selecting H<sub>2</sub>O or CH<sub>4</sub> measurement.
- Note 2) Specify the same range for CO and CO<sub>2</sub>.
- Note 3) Specify the measuring range within the limit calculated based on the optical path length (See Page 1).
- Note 4) Cable length between receiver and control unit: when you select the code "X", available length is 10 m or longer.
- Note 5) Cable length between receiver and transmitter: when you select the code "X", available length is 5 m or longer.
- Note 6) When the optical path length is 10 m, select "9" in 18th, 19th, and 20th codes.
- Note 7) For single component analyzer, select "Y". For two-component analyzer, select a range for the second component.
- Note 8) From 23th code, this specify particular specification according to delivery specification.

## LIST FOR COMBINATIONS OF MEASURABLE COMPONENTS, UNITS AND MEASUREMENT RANGES

Component	Measuring range	
CO	0 – 2, 2.5, 4, 5, 10, 15, 20, 25, 50, 100 vol%	
CO (Low concentration)	0 – 200, 250, 400, 500, 1000, 2000, 5000 ppm or mg/m <sup>3</sup> 0 – 2 vol%	
HCl	0 – 10, 15, 20, 25, 50, 100, 200, 250, 400, 500, 1000, 2000, 5000 ppm or mg/m <sup>3</sup>	
CO <sub>2</sub>	0 – 2, 2.5, 4.5, 10, 15, 20, 25, 50, 100 vol%	
O <sub>2</sub>	0 – 10, 15, 20, 25, 50, 100 vol%	
O <sub>2</sub> (High temp.)	0 – 4, 5, 10, 15, 20, 25, 50, 100 vol%	
O <sub>2</sub> (Instrument air purge)	0 – 25, 50, 100 vol%	
CH <sub>4</sub>	0 – 100, 200, 250, 400, 500, 1000, 2000, 5000 ppm or mg/m <sup>3</sup> 0 – 2, 2.5, 4, 5, 10, 15, 20, 25, 50, 100 vol%	
NH <sub>3</sub>	0 – 15, 20, 25, 50, 100, 200, 250, 400, 500, 1000, 2000, 5000 ppm or mg/m <sup>3</sup>	
CO + CO <sub>2</sub>	1st comp.: CO	0 – 2.5, 4, 5, 10, 15, 20, 25, 50, 100 vol%
	2nd comp.: CO <sub>2</sub>	0 – 2.5, 4, 5, 10, 15, 20, 25, 50, 100 vol%

## BASIC PRINCIPLE

ZSS uses the near-infrared semiconductor laser as the light source, and photo-diode as photodetector. Each gas component has its own wavelength range where it absorbs the light, and a wavelength range consists of a set of many absorption lines, as shown in the figures below. As ZSS can aim at only one absorption-line among them, the measurement principally receives no interference from other gases. ZSS also focus on the amplitude of modulated signal, instead of the amount of change in light intensity, to detect gas concentration.

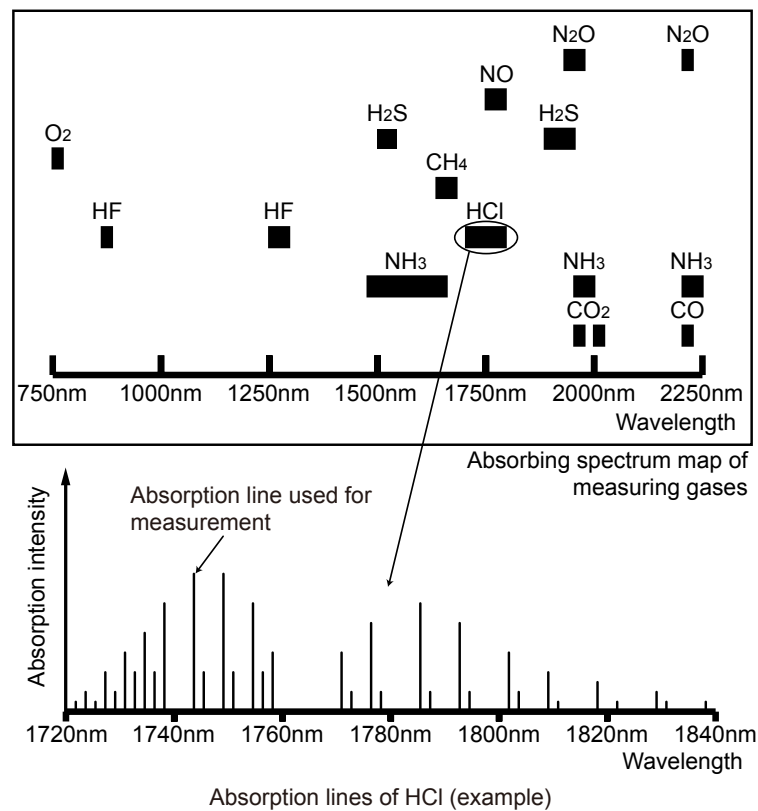

# NECESSARY ITEMS TO BE ORDERED SEPARATELY

## 1. Purging equipment

Purging equipment is indispensable for the laser gas analyzer to remove dust and mist from the transmitter unit and the receiver unit. We offer the following three types:

A set of equipment in a box, a set of equipment without box, or each single equipment.

### 1.1 A set of purging equipment in a box

Item	Model
Purging equipment in a box: flowmeter scale 4–50 L/min	ZZP*ZSSTQ505307C2
Purging equipment in a box: flowmeter scale 20–100 L/min	ZZP*ZSSTQ505307C1
Purging equipment in a box: flowmeter scale 30–300 L/min	ZZP*ZSSTQ505307C3

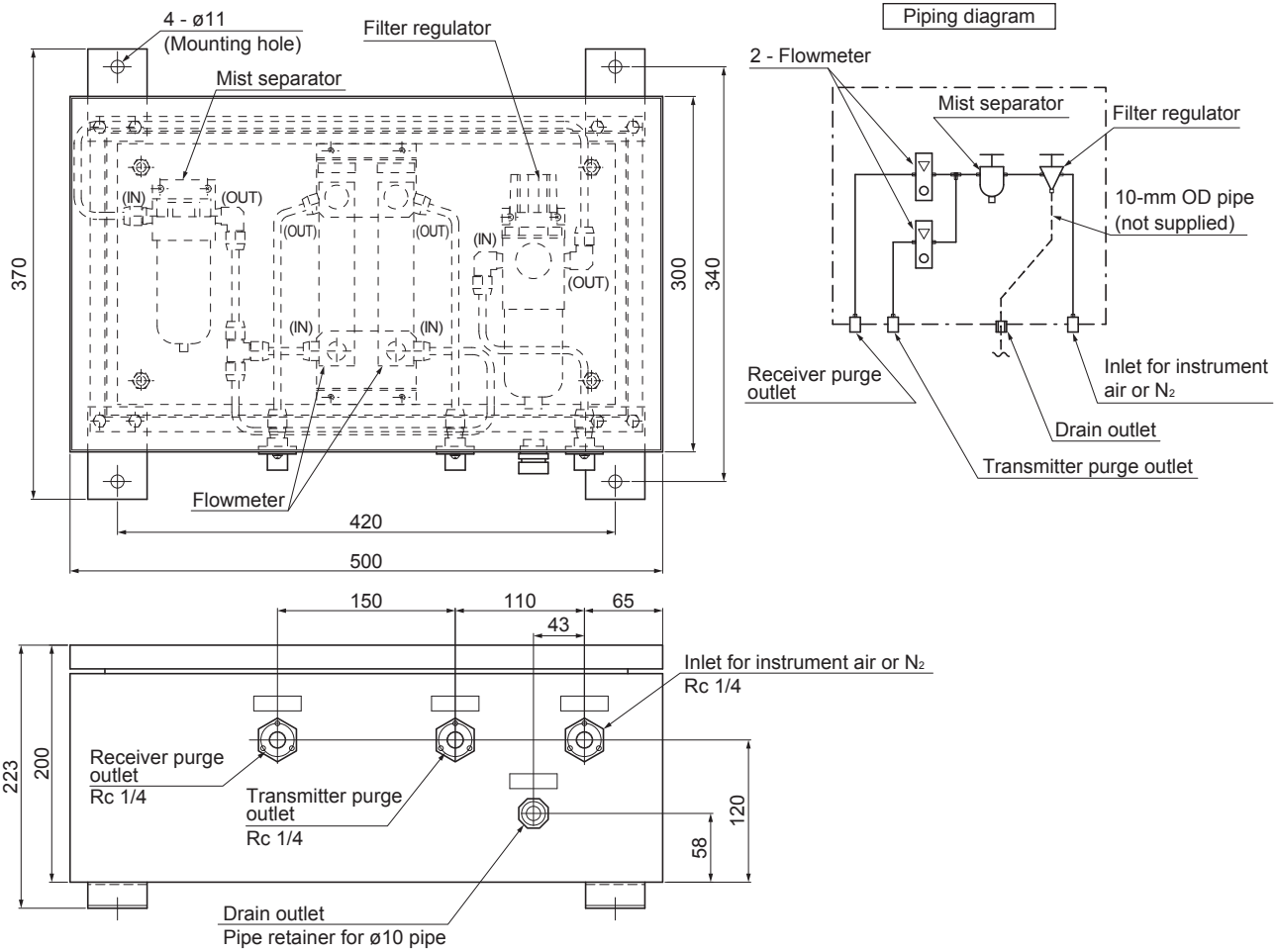

### 1.2 A set of purging equipment without box

Item	Model	Remarks
Purging equipment without box: flowmeter scale 4–50 L/min	ZZP*ZSSTQ505299C2	With PTFE tube
Purging equipment without box: flowmeter scale 20–100 L/min	ZZP*ZSSTQ505299C1	
Purging equipment without box: flowmeter scale 30–300 L/min	ZZP*ZSSTQ505299C3	

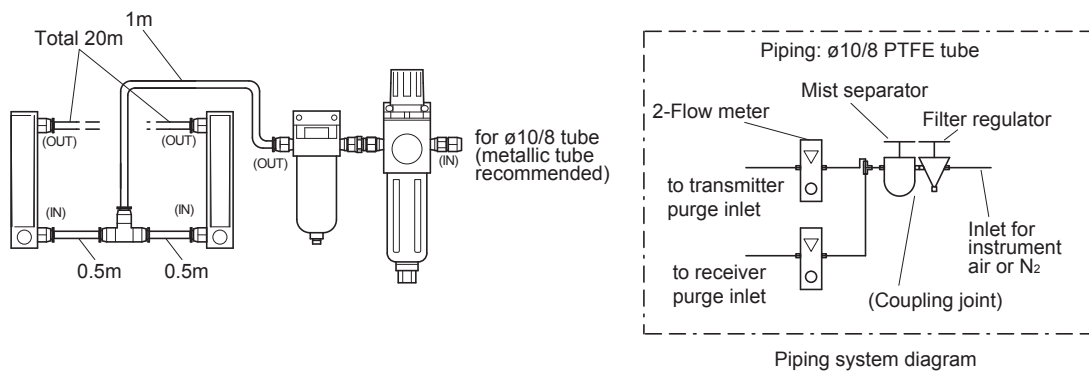

### 1.3 Purging equipment

Item	Q'ty	Model
Flowmeter with 4–50 L/min scale	2	ZZP*ZSSTQ505309P2
Flowmeter with 20–100 L/min scale	2	ZZP*ZSSTQ505309P1
Flowmeter with 30–300 L/min scale	2	ZZP*ZSSTQ505308P1
Filter regulator	1	ZZP*ZSSTQ505311P1
Mist separator	1	ZZP*ZSSTQ505310P1
R 1/4 cap nut for mist separator	1	ZZP*ZSSR850N000075

### 2. Zero/span calibration equipment

To carry out calibration, remove the angle adjustment unit, and install the following equipment, and then flow the zero gas or span gas.

	Item	Q'ty	Model
(1)	Calibration gas cell (for HCl, NH <sub>3</sub> , CO, CO <sub>2</sub> , CO + CO <sub>2</sub> , CH <sub>4</sub> )*1	1	ZZP*ZSSTQ404735C1
	Calibration gas cell (for HCl + H <sub>2</sub> O, NH <sub>3</sub> + H <sub>2</sub> O, O <sub>2</sub> )*1	1	ZZP*ZSSTQ404736C1
(2)	Cable btwn the receiver unit and the control unit (5 m)	1	ZZP*ZSSTQ404686C2
(3)	Cable btwn the receiver unit and the transmitter unit (1.6 m)	1	ZZP*ZSSTQ404685C3
(4)	Pressure regulator	1	ZBD6
(5)	Flowmeter (1.5–2.0 L/min)	1	ZBD4

\*1: The standard length of the calibration gas cell is 1 m. Consult us if a low concentration gas cylinder is difficult to obtain.

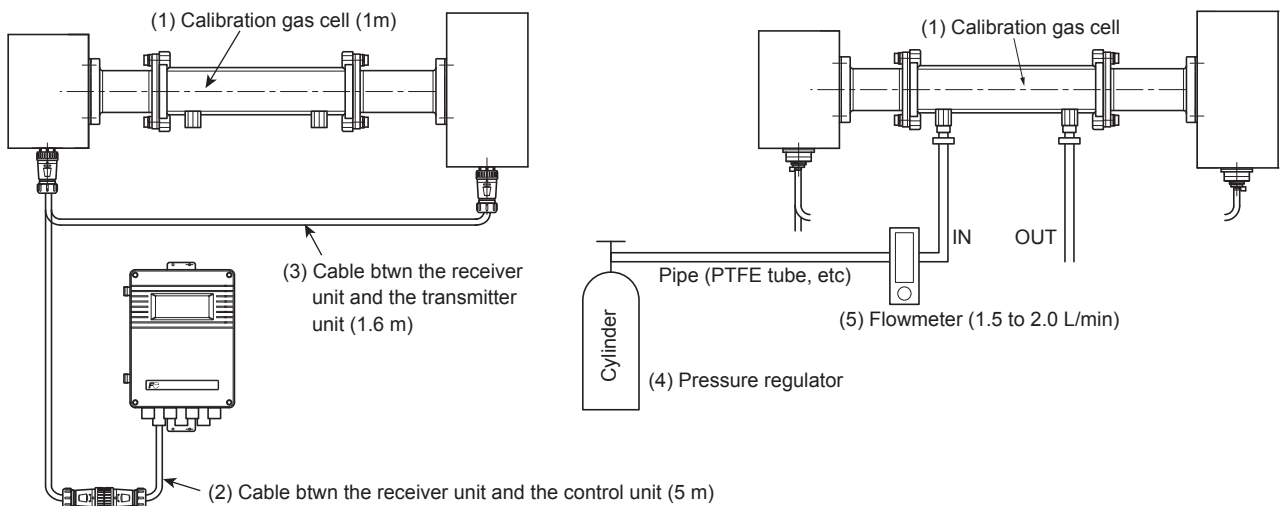

### 3. Optical axis adjusting tool

You can adjust the optical axis by aiming the laser pointer to the center of the target.

#### 3.1 Optical axis adjusting tool

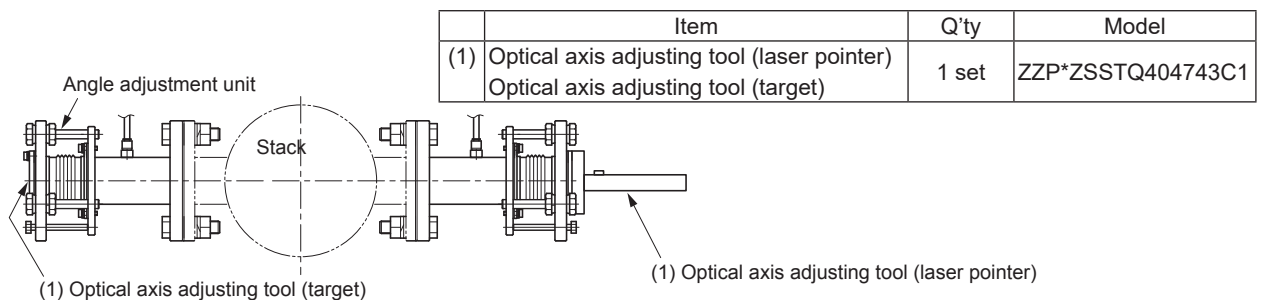

#### 3.2 BNC cable for optical adjustment

After installing the transmitter unit, the receiver unit, and the control unit, connect a digital voltmeter through the BNC cable to the transmitter unit or the receiver unit. Adjust the optical axis so that the voltage indicated on the voltmeter becomes the relevant value.

Item	Q'ty	Model
BNC cable for optical adjustment	1	ZZP*ZSSTQ505298C1

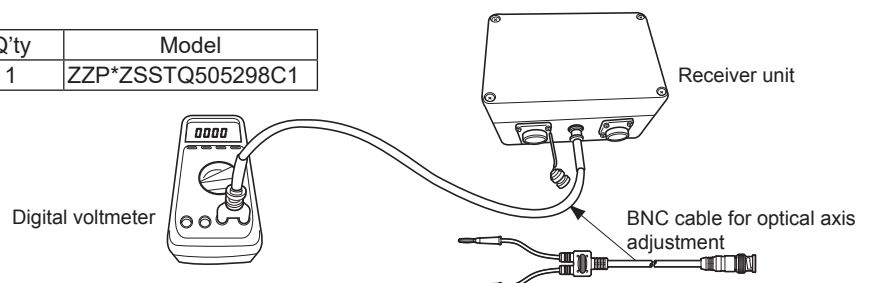



4. IR card (IR visualizer) for NH<sub>3</sub>

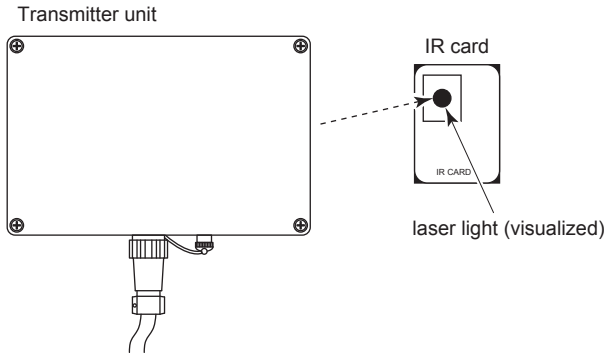

Item	Q'ty	Model
IR card (for NH <sub>3</sub> )	1	ZZP*ZSSTQ505315P1

5. Check cell

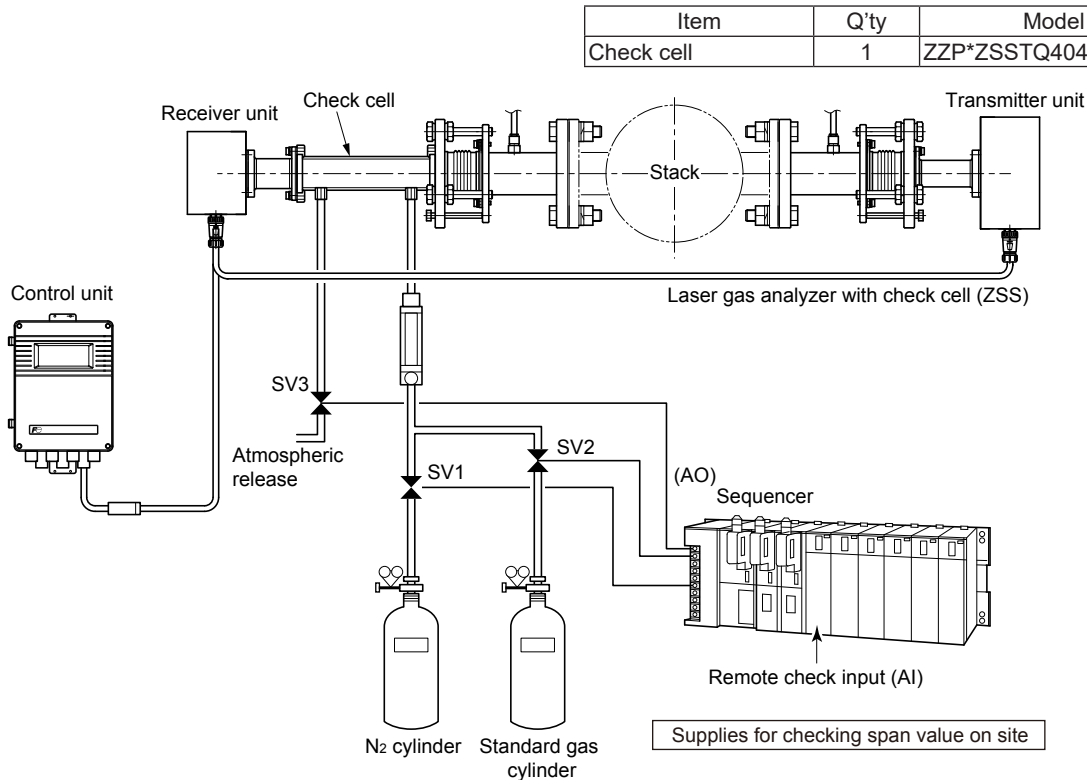

Item	Q'ty	Model
Check cell	1	ZZP*ZSSTQ404742C1

SCOPE OF DELIVERY

- Control unit
- Transmitter unit
- Receiver unit
- Angle adjustment units (two units, one for transmitter unit and the other for receiver unit)
- Cable between the transmitter unit and the receiver unit (specified length)
- Cable between the receiver unit and the control unit (specified length)
- Standard accessories
- Instruction manual

NECESSARY ITEMS TO BE ORDERED SEPARATELY

- Purging equipment ..... See Page 6
- Zero/span calibration equipment \*1 ..... See Page 7
- Optical axis adjustment tool \*1 ..... See Page 7
- Spare parts for one year

\*1: The calibration equipment and the optical axis adjustment tool are not required for every gas analyzer, but required at least one set for one site.

STANDARD ACCESSORIES

Item	Q'ty	Specification
Bolt	8 or 16 *1	M16 × 55 (70) **, stainless steel
Nut	8 or 16 *1	M16, stainless steel
Spring washer	8 or 16 *1	M16, stainless steel
Flat washer	8 or 16 *1	M16, stainless steel
Companion flange packing or flange packing for use in high temperature	2	According to flange specification
Bolt for angle adjustment	6	Hex socket bolt M8 × 70
Power supply fuse	2	
Bolt for connecting receiving unit and transmitter unit	12	Hex socket bolt M5 × 12

Notes:

1. When the 9th code is "B", 16 pieces are provided. For other cases, 8 pieces are provided.
2. When the 9th code is "A", the bolt length is 55 mm. When the 9th code is "B", "C", or "D", the bolt length is 70 mm. Inch-sized bolts are not supplied.

SPARE PARTS FOR ONE YEAR (ZBN1SS12)

Name	Quantity	Remarks
Silicone packing A	2 pieces	For bellows (ZZP*ZSSTQ505205P1)
O-ring	2 pieces	(ZZP*ZSSR8552850)



# DIMENSIONS (in mm)

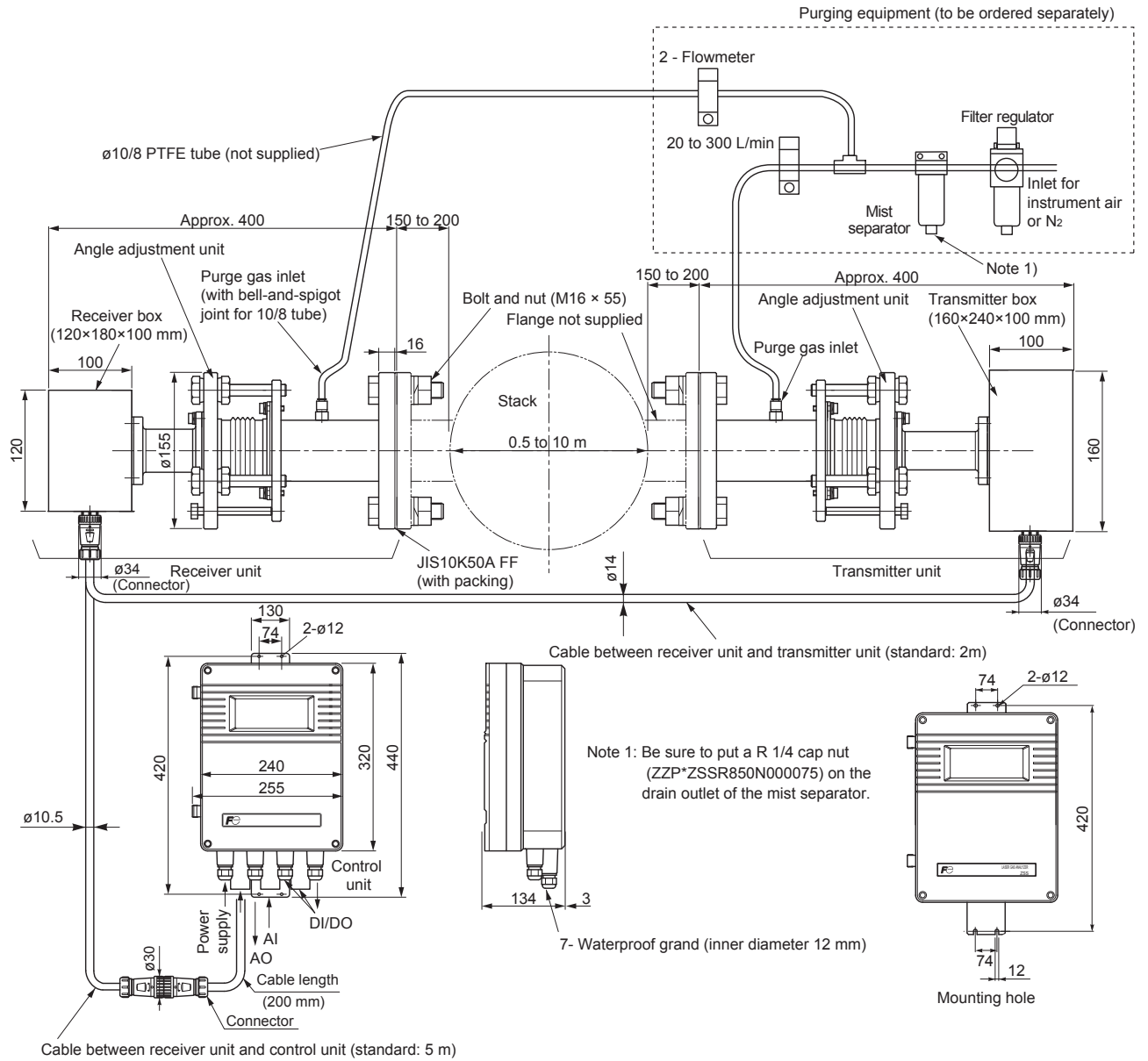

**Notes:**

- For O<sub>2</sub> analyzers other than the instrument air purge version, use N<sub>2</sub>. For all the other cases, use instrument air. If you use air that contains oil and/or mist, the purge gas flow decreases due to the contaminant, which adversely affect the measurement. In such a case, frequent maintenance is required, and in some cases you may have to install a filter additionally.
- Once you install the analyzer, you have to purge the equipment with instrument air or N<sub>2</sub> regardless if the analyzer and the furnace are in operation or not. If you operate the furnace without purging, it may cause the fatal damage to the optical part.

## ANGLE ADJUSTMENT UNIT

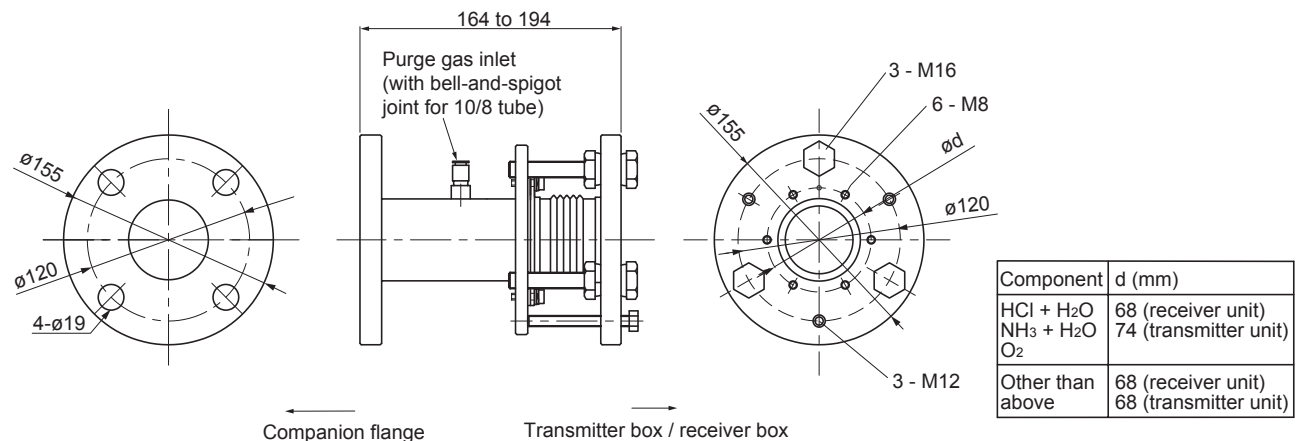

## CONNECTION DIAGRAM

### Power terminal



M4 screw

- 1 100-240 V AC, 50/60 Hz (L)
- 2 100-240 V AC, 50/60 Hz (N)

### PE terminal

PE Protective earth  
M4 screw

### AI/AO/DI/DO terminal

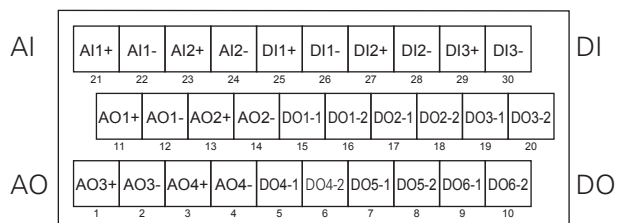

M3 screw

Cross-sectional area of wire: AWG26-16

### AO terminals

- 11 AO1+ } Analog output 1 (AO1)
- 12 AO1- }
- 13 AO2+ } Analog output 2 (AO2)
- 14 AO2- }
- 1 AO3+ } Analog output 3 (AO3) (AO extension board is required)
- 2 AO3- }
- 3 AO4+ } Analog output 4 (AO4) (AO extension board is required)
- 4 AO4- }

### AI terminals

- 21 AI1+ } Analog input 1 (AI1)
- 22 AI1- }
- 23 AI2+ } Analog input 2 (AI2)
- 24 AI2- }

### DI terminals

- 25 DI1+ } Average resetting signal (option)
- 26 DI1- }
- 27 DI2+ } Instantaneous/average switching signal (option)
- 28 DI2- }
- 29 DI3+ } AO holding signal (option)
- 30 DI3- }

### DO terminals

- 15 DO1-1 } Light intensity low
- 16 DO1-2 }
- 17 DO2-1 } Device failure
- 18 DO2-2 }
- 19 DO3-1 } During hold/during calibration
- 20 DO3-2 }
- 5 DO4-1 } Overrange/underrange
- 6 DO4-2 }
- 7 DO5-1 } Environmental error
- 8 DO5-2 }
- 9 DO6-1 } Power interruption
- 10 DO6-2 }

### Notes:

- Device failure includes laser temperature error, communication error, and overrange.
- Environmental error includes gas temperature error, purge air pressure underrange, analog input signal error, and box temperature error.
- Consult us if you want to use any alarms (relay outputs) dependent on the installation environment.
- It takes at least 5 minutes until all the alarms except for the communication error start to work.  
Alarm for "light intensity low" is triggered if the alarm status continues at least 1 minute, which means 6 minutes after the power is turned on.
- AI terminal, AO terminal, and DI/DO terminal are all on the same board.

## MOUNTING DIMENSIONS (in mm)

Keep purging the analyzer once you install it on a stack.  
Otherwise, the contamination of optical surface may result in the analyzer failure.

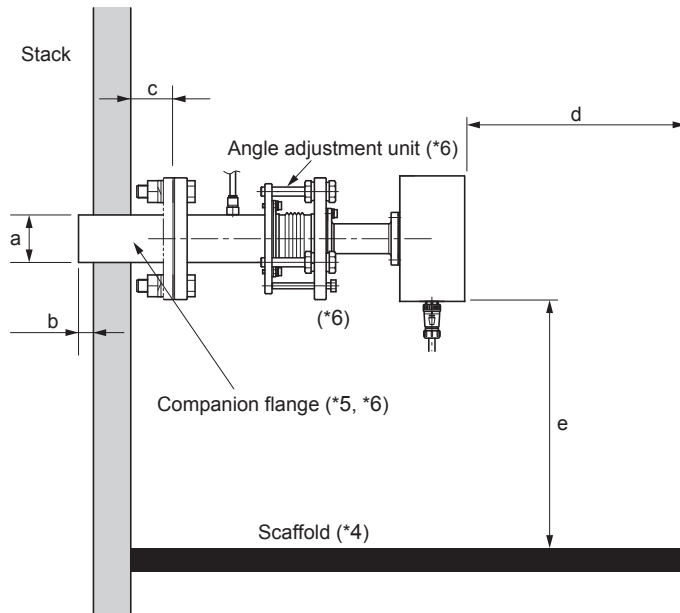

- a: inside diameter  $\geq 50$  mm
- b: 20 to 70 mm (\*1)
- c:  $\geq$  approx. 200 mm (\*2)
- d:  $\geq 400$  mm (\*3)
- e: 500 to 1500 mm(\*3)

- \*1: When the flue gas contains a large amount of dust, ensure the minimum length of 50 mm.
- \*2: When the flue gas temperature is high (400°C or more), ensure the minimum distance of 400 mm.  
Note that in that case you have to be even more careful in adjusting the angle of the companion flange because the angle range within which the companion flange can be adjusted is narrow.
- \*3: Make sure to install the analyzer in the place where it is easy to operate, and where there is enough clearance.
- \*4: Scaffold is required for both the receiver unit side and the transmitter unit side.
- \*5: Use a flanged valve where there is a risk of gas blowout or where the operator may be exposed to a dangerous situation.
- \*6: Tightening torque for the companion flange shall be  $118 \pm 14$  N·m. When tightening the bolts of the flange or the angle adjustment unit, apply grease to the bolts. (Recommended grease is the one contains molybdenum.)

## ROUGH GUIDE TO MOUNT THE COMPANION FLANGE

When  $\theta$  is larger than  $5^\circ$ , attach the companion flange with the  $\gamma$  angle  $\leq 5^\circ$  inside the circumference of radius A.

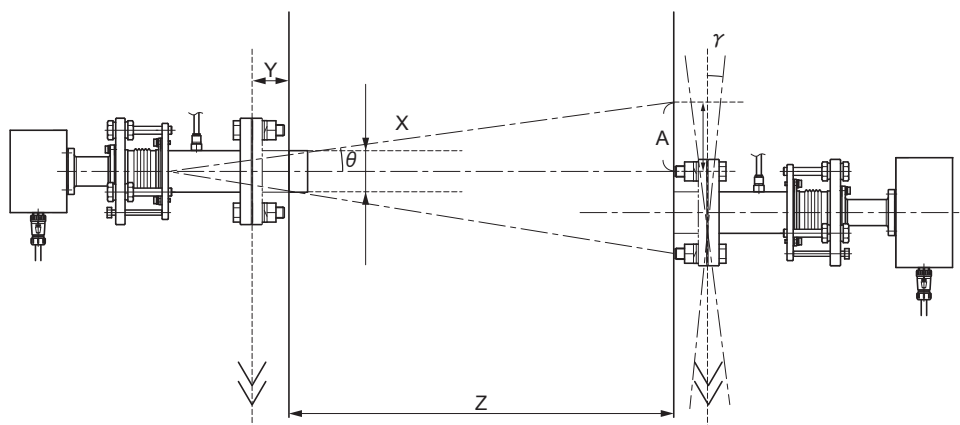

- X: Flange inner diameter of receiver unit and transmitter unit
- Y: Distance between the outer wall of the stack and each flange of the transmitter unit and the receiver unit
- Z: Inner diameter of stack

$$\theta = \tan^{-1} \frac{X}{2(Y + 125)}$$

$$A \approx 0.087 \times (Z + Y + 125)$$

$$\tan 5^\circ \approx 0.087$$

Please specify the following items when you contact us for inquiry.

- Code symbol ZSS
- Parameter of target gas

Item	Min. value	Typical value	Max. value
Concentration range of target gas			
Temperature (°C)			
Pressure (kPa)			
Flow velocity (m/s)			
Moisture (vol%)			
Dust (mg/m <sup>3</sup> (N))			
Other gas component (vol%/ppm)			
Other gas component (vol%/ppm)			
Other gas component (vol%/ppm)			

- Stack inner diameter (optical path length) A  m
- Distance from stack (outside wall) to flange B  m
- Distance from stack (outside wall) to flange C  m
- Cable between receiver unit and control unit D  m
- Cable between receiver unit and transmitter unit E  m

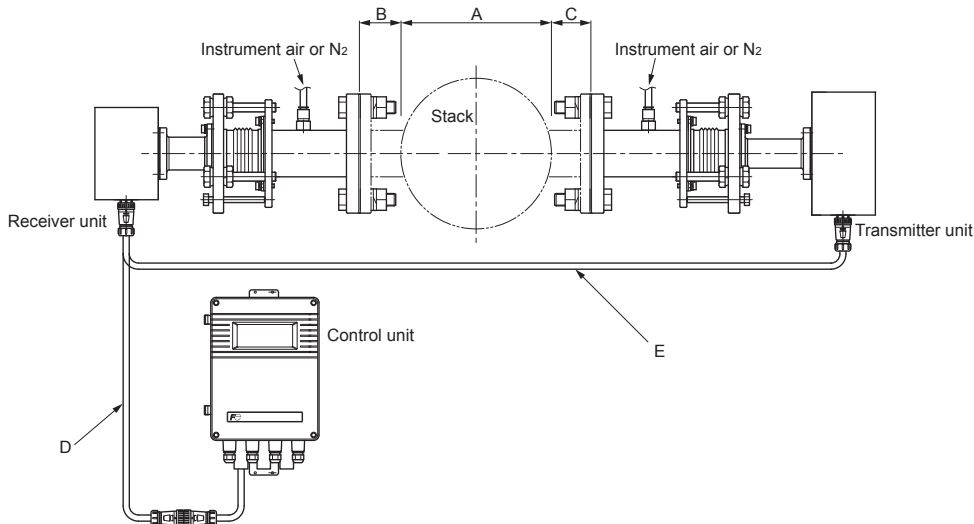

- Spares for 1-year measurement no need / necessary
- Separate order items no need / necessary
- Output of O<sub>2</sub> correction value (only for HCl, NH<sub>3</sub> and CO meter) no need / necessary
- Reference O<sub>2</sub> concentration value (vol%) (When "necessary" is selected in 10) \_\_\_\_\_ vol%
- Presence of vibration No / Yes ( \_\_\_\_\_ G)

**⚠ Safety information**

- Be sure to read thoroughly the instruction manual before use.
- When this product is installed in a flue and as long as no one enters in the flue, this product can be used as Class 1 laser product. However, be sure to follow the instructions below for safety because the product emits laser beam when energized.
  - Do not remove the transmitter unit, the receiver unit, or any part of them from the flue without our permission. Otherwise, it may cause a loss of eyesight and/or skin lesion. Consult us if there is a need for removal.
  - O<sub>2</sub> analyzer for high temperature and instrument air purge version O<sub>2</sub> analyzer use the Class 3B laser elements. When anyone enters into the flue, this product is regarded as a Class 3B product. In this case, safety measures are required; for example, an entrance detection system, an interlock that stops radiation of laser beam, etc. Consult us for details.

Information in this catalog is subject to change without notice.  
Read the instruction manuals thoroughly before using the products.



Gate City Ohsaki, East Tower, 11-2, Osaki 1-chome, Shinagawa-ku, Tokyo 141-0032, Japan  
Phone: +81-3-5435-7111  
www.fujielectric.com  
www.fujielectric.com/products/instruments/